

MENIIT

NEET | IIT-JEE | FOUNDATION

Corporate Office: 44-A/1, Kalu Sarai, New Delhi 110016 | Web: www.meniit.com

JEE Advanced : Paper-2 (2013)

IMPORTANT INSTRUCTIONS

A. General:

1. This booklet is your Question Paper. Do not break the seals of this booklet before being instructed to do so by the invigilators.
2. Blank papers, clipboards, log tables, slide rules, calculators, cameras, cellular phones, pagers and electronic gadgets are NOT allowed inside the examination hall.
3. Write your name and roll number in the space provided on the back cover of this booklet.
4. Answers to the questions and personal details are to be filled on a two-part carbon-less paper, which is provided separately. These parts should only be separated at the end of the examination when instructed by the invigilator. The upper sheet is a machine-gradable Objective Response Sheet (ORS) which will be retained by the invigilator. You will be allowed to take away the bottom sheet at the end of the examination.
5. **Using a black ball point pen darken the bubbles on the upper original sheet.** Apply sufficient pressure so that the impression is created on the bottom duplicate sheet.

B. Question Paper Format

6. The question paper consists of three parts (Physics, Chemistry and Mathematics). Each part consists of three sections.
Section 1 contains **8 multiple choice questions**. Each question has four choices (A), (B), (C) and (D) out of which **ONE OR MORE are correct**
7. **Section 2** contains **4 paragraphs** each describing theory, experiment, data etc. **Eight questions** relate to four paragraphs with two questions on each paragraph. Each question of a paragraph has **ONLY ONE correct answer** among the four choices (A), (B), (C) and (D).
8. **Section 3** contains **4 multiple choice questions** relate to four paragraphs with two questions on each paragraph. Each question of a paragraph has **ONLY ONE CORRECT ANSWER** among the four choices (A), (B), (C) and (D).

C. Marking Scheme

9. For each question in **Section 1**, you will be awarded **3 marks** if you darken all the bubble(s) corresponding to only the correct answer(s) and **zero mark** if no bubbles are darkened. In all other cases, **minus one (-1) mark** will be awarded.
10. For each question **Section 2 and 3**, you will be awarded **3 marks** if you darken the bubble corresponding to only the correct answer and **zero mark** if no bubbles are darkened. In all other cases, **minus one (-1) mark** will be awarded.

PART-A : PHYSICS

Section - 1 :

(Only One option correct Type)

This section contains **8 multiple choice questions**. Each question has four choices (A), (B), (C) and (D) out of which **ONE or MORE** are correct.

1. Two non-conducting spheres of radii R_1 and R_2 and carrying uniform volume charge densities $+\rho$ and $-\rho$, respectively, are placed such that they partially overlap, as shown in figure. At all points in the overlapping region,

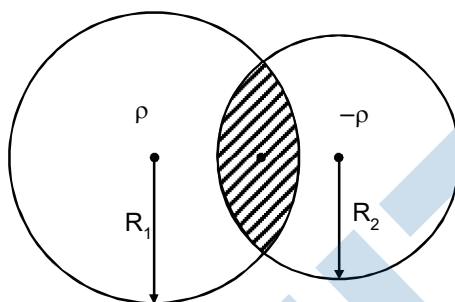

- (A) the electrostatic field is zero
 (B) the electrostatic potential is constant
 (C*) the electrostatic field is constant in magnitude
 (D*) the electrostatic field has same direction.

Ans. [CD]

Sol.
$$\frac{\rho \vec{OA}}{3\epsilon_0} + \frac{\rho \vec{AO'}}{3\epsilon_0} = \frac{\rho \vec{\ell}}{3\epsilon_0}$$

2. Using the expression $2d \sin \theta = \lambda$, one calculates the values of d by measuring the corresponding angles θ in the range 0 to 90° . The wavelength λ is exactly known and the error in θ is constant for all values of θ . As θ increases from 0° ,
- (A) the absolute error in d remains constant
 (B) the absolute error in d increases
 (C) the fractional error in d remains constant
 (D*) the fractional error in d decreases.

Ans. [D]

Sol.
$$d = \frac{\lambda}{2 \sin \theta}$$

$$\Delta d = \frac{-\lambda}{2} \sin \theta \cos \theta d \theta$$

$$\frac{\Delta d}{d} = \frac{-\lambda \cos \theta}{2 \sin^2 \theta} \frac{\lambda}{2 \sin \theta}$$

3. The radius of the orbit of an electron in a Hydrogen-like atom is $4.5 a_0$, where a_0 is the Bohr radius. Its orbital angular momentum is $\frac{3h}{2\pi}$. It is given that h is Planck constant and R is Rydberg constant. The possible wavelength (s), when the atom de-excites, is (are)

(A*) $\frac{9}{32R}$ (B) $\frac{9}{16R}$ (C*) $\frac{9}{5R}$ (D) $\frac{9}{3R}$

Ans. [AC]

Sol. $4.5a_0 = \frac{n^2 a_0}{z}$

$4.5 = \frac{9}{z} \Rightarrow z = 2$

$\frac{1}{\lambda} = 4R \left(\frac{1}{1^2} - \frac{1}{3^2} \right) \Rightarrow \lambda = \frac{9}{32R}$

$\frac{1}{\lambda} = 4R \left(\frac{1}{2^2} - \frac{1}{3^2} \right) \Rightarrow \lambda = \frac{9}{5R}$

$\frac{1}{\lambda} = 4R \left(\frac{1}{1^2} - \frac{1}{2^2} \right) \Rightarrow \lambda = \frac{3}{R}$

4. The figure below shows the variation of specific heat capacity (C) of a solid as a function of temperature (T). The temperature is increased continuously from 0 to 500 K at a constant rate. Ignoring any volume change, the following statement (s) is (are) correct to reasonable approximation.

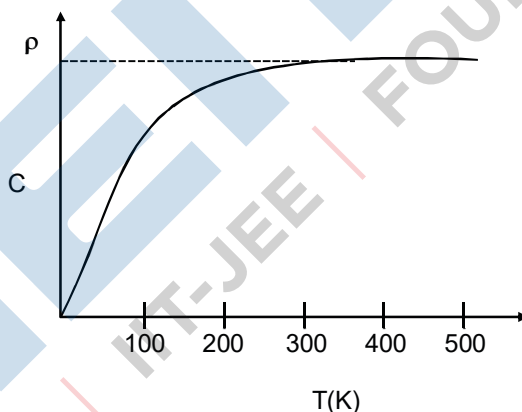

- (A*) the rate at which heat is absorbed in the range 0-100 K varies linearly with temperature T.
 (B*) heat absorbed in increasing the temperature from 0-100 K is less than the heat required for increasing the temperature from 400 - 500 K.
 (C*) there is no change in the rate of heat absorption in the range 400 - 500 K
 (D*) the rate of heat absorption increases in the range 200 - 300 K.

Ans. [ABCD or BCD]

Sol. $\frac{dQ}{dt} = mc \frac{dT}{dt}$

5. A particle of mass m is attached to one end of a mass-less spring of force constant k , lying on a frictionless horizontal plane. The other end of the spring is fixed. The particle starts moving horizontally from its equilibrium position at time $t = 0$ with an initial velocity u_0 . When the speed of the particle is $0.5 u_0$, it collides elastically with a rigid wall.

(A*) the speed of the particle when it returns to its equilibrium position is u_0

(B) the time at which the particle passes through the equilibrium position for the first time is $t = \pi \sqrt{\frac{m}{k}}$

(C) the time at which the maximum compression of the spring occurs is $t = \frac{4\pi}{3} \sqrt{\frac{m}{k}}$

(D*) the time at which the particle passes through the equilibrium position for the second time is

$$t = \frac{5\pi}{3} \sqrt{\frac{m}{k}}$$

Ans. [AD]

Sol. $\frac{\omega A}{2} = \omega \sqrt{A^2 - x^2}$

$$x = \frac{\sqrt{3}A}{2}$$

$$\omega t = \frac{2\pi}{3}$$

$$\sqrt{\frac{k}{m}} t = \frac{2\pi}{3}$$

$$t_1 = \left(\frac{2\pi}{3} + \frac{\pi}{2} \right) \sqrt{\frac{m}{k}}$$

$$t_2 = \left(\frac{2\pi}{3} + \pi \right) \sqrt{\frac{m}{k}}$$

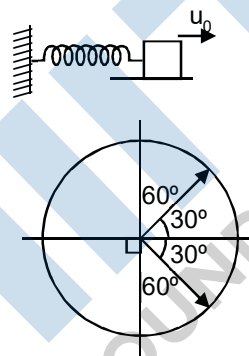

6. Two bodies each of mass M , are kept fixed with a separation $2L$. A particle of mass m is projected from the midpoint of the line joining their centres, perpendicular to the line. The gravitational constant is G . The correct statement (s) is (are)

(A) The minimum initial velocity of the mass m to escape the gravitational field of the two bodies is 4

$$\sqrt{\frac{GM}{L}}$$

(B*) The minimum initial velocity of the mass m to escape the gravitational field of the two bodies is 2

$$\sqrt{\frac{GM}{L}}$$

(C) The minimum initial velocity of the mass m to escape the gravitational field of the two bodies is $\sqrt{\frac{2GM}{L}}$

(D*) The energy of the mass m remains constant

Ans. [BD]

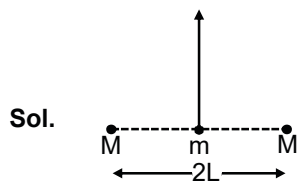

$$\frac{GMm}{L} \times 2 = \frac{1}{2}mv^2$$

$$v = 2\sqrt{\frac{am}{L}}$$

energy of system is constant, not of the mass m

7. Two vehicles, each moving with speed u on the same horizontal straight road, are approaching each other. Wind blows along the road with velocity w . One of these vehicles blows a whistle of frequency f_1 . An observer in the other vehicle hears the frequency of the whistle to be f_2 . The speed of sound in still air is V . The correct statement (s) is (are)
- (A*) If the wind blows from the observer to the source, $f_2 > f_1$
 - (B*) If the wind blows from the source to the observer, $f_2 > f_1$
 - (C) If the wind blows from observer to the source, $f_2 < f_1$
 - (D) If the wind blows from the source to the observer, $f_2 < f_1$

Ans. [AB]

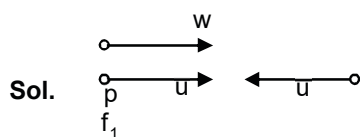

$$f_2 = \frac{V + w + u}{V + w - u} f_1 \quad \text{or} \quad f_2 = \frac{(V - w) + u}{(V - w) - u} f_1$$

8. A steady current I flows along an infinitely long hollow cylindrical conductor of radius R . This cylinder is placed coaxially inside an infinite solenoid of radius $2R$. The solenoid has n turns per unit length and carries a steady current I . Consider a point P at a distance r from the common axis. The correct statement (s) is (are)
- (A*) In the region $0 < r < R$, the magnetic field is non-zero.
 - (B) In the region $R < r < 2R$, the magnetic field is along the common axis.
 - (C) In the region $R < r < 2R$, the magnetic field is tangential to the circle of radius r , centered on the axis.
 - (D*) In the region $r > 2R$, the magnetic field is non-zero.

Ans. [AD]

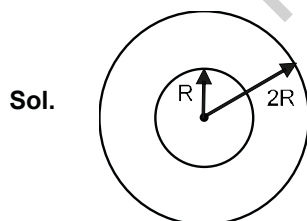

Section - II

(Paragraph Type)

This section contains **4 paragraphs** each describing theory, experiment, data etc. **Eight questions** relate to four paragraphs with two questions on each paragraph. Each questions of a paragraph has **only one correct answer** among the four choices (A), (B), (C) and (D).

Paragraph for Questions 9 to 10

A point charge Q is moving in a circular orbit of radius R in the x - y plane with an angular velocity ω . This can be considered as equivalent to a loop carrying a steady current $\frac{Q\omega}{2\pi}$. A uniform magnetic field along the positive z -axis is now switched on, which increases at a constant rate from 0 to B in one second. Assume that the radius of the orbit remains constant. The application of the magnetic field induces an emf in the orbit. The induced emf is defined as the work done by an induced electric field in moving a unit positive charge around a closed loop. It is known that, for an orbiting charge, the magnetic dipole moment is proportional to the angular momentum with a proportionality constant γ .

9. The change in the magnetic dipole moment associated with the orbit, at the end of the time interval of the magnetic field change, is

(A) $-\gamma BQR^2$ (B*) $-\gamma \frac{BQR^2}{2}$ (C) $\gamma \frac{BQR^2}{2}$ (D) γBQR^2

Ans. [B]

Sol. $M = \gamma L$

$$\frac{dM}{dt} = \gamma \frac{dL}{dt} = \gamma \tau$$

$$\tau = \frac{Id\omega}{dt}$$

$$2\pi RE = \frac{dB}{dt} \pi R^2$$

$$QER = \tau = \frac{Id\omega}{dt}$$

$$QER = \frac{QdB R^2}{dt 2}$$

$$\frac{dM}{dt} = \gamma \times \frac{QR^2}{2} \frac{dB}{dt}$$

10. The magnitude of the induced electric field in the orbit at any instant of time during the time interval of the magnetic field change is

(A) $\frac{BR}{4}$ (B*) $\frac{BR}{2}$ (C) BR (D) $2BR$

Ans. [B]

Sol. $E = \frac{dB}{dt} \frac{R}{2}$

Paragraph for Questions 11 to 12

The mass of a nucleus ${}^A_Z X$ is less than the sum of the masses of $(A-Z)$ number of neutrons and Z number of protons in the nucleus. The energy equivalent to the corresponding mass difference is known as the binding energy of the nucleus. A heavy nucleus of mass M can break into two light nuclei of masses m_1 and m_2 only if $(m_1 + m_2) < M$. Also, two light nuclei of masses m_3 and m_4 can undergo complete fusion and form a heavy nucleus of mass M' only if $(m_3 + m_4) > M'$. The masses of some neutral atoms are given in the table below :

${}^1_1\text{H}$	1.007825u	${}^2_1\text{H}$	2.014102u	${}^3_1\text{H}$	3.016050u	${}^4_2\text{He}$	4.002603u
${}^6_3\text{Li}$	6.015123u	${}^7_3\text{Li}$	7.016004u	${}^{70}_{30}\text{Zn}$	69.925325u	${}^{82}_{34}\text{Se}$	81.916709u
${}^{152}_{64}\text{Gd}$	151.919803u	${}^{206}_{82}\text{Pb}$	205.974455u	${}^{209}_{83}\text{Bi}$	208.980388u	${}^{210}_{84}\text{Po}$	209.982876u

$(1u = 932 \text{ MeV}/c^2)$

11. The kinetic energy (in keV) of the alpha particle, when the nucleus ${}^{210}_{84}\text{Po}$ at rest undergoes alpha decay, is
 (A*) 5319 (B) 5422 (C) 5707 (D) 5818

Ans. [A]

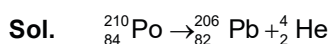

$$Q = (m_{\text{Po}} - m_{\text{pb}} - m_{\alpha}) c^2$$

$$= \frac{209.982876}{4.008421} - \frac{205.974455}{4.008421} - \frac{4.002603}{4.008421}$$

$$= 0.005818 \times 932 \text{ MeV}$$

$$= 5422 \text{ keV}$$

Almost 100 keV go to nucleus
 $\Rightarrow k_{\alpha} = 5319 \text{ keV}$

12. The correct statement is
 (A) The nucleus ${}^6_3\text{Li}$ can emit an alpha particle.
 (B) The nucleus ${}^{210}_{84}\text{Po}$ can emit a proton.
 (C*) Deuteron and alpha particle can undergo complete fusion.
 (D) The nuclei ${}^{70}_{30}\text{Zn}$ and ${}^{82}_{34}\text{Se}$ can undergo complete fusion.

Ans. [C]

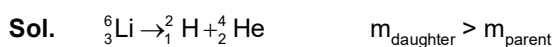

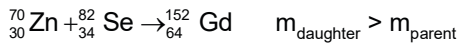

Paragraph for Questions 13 to 14

A small block of mass 1 kg is released from rest at the top of a rough track. The track is a circular arc of radius 40 m. The block slides along the track without toppling and a frictional force acts on it in the direction opposite to the instantaneous velocity. The work done in overcoming the friction up to the point Q, as shown in the figure below, is 150 J. (Take the acceleration due to gravity, $g = 10 \text{ ms}^{-2}$)

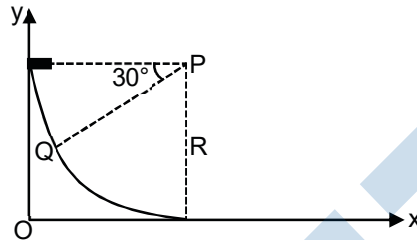

13. The magnitude of the normal reaction that acts on the block at the point Q is
 (A*) 7.5 N (B) 8.6 N (C) 11.5 N (D) 22.5 N

Ans. [A]

14. The speed of the block when it reaches the point Q is
 (A) 5 ms^{-1} (B*) 10 ms^{-1} (C) $10\sqrt{3} \text{ ms}^{-1}$ (D) 20 ms^{-1}

Ans. [B]

Sol. $\frac{1}{2}mv^2 = mg\frac{R}{2} - 150$
 $= 1 \times 10 \times 20 - 150 = 50$
 $v = 10 \text{ m/s}$
 $N - 10 \cos 60^\circ = \frac{mv^2}{40}$
 $N = 5 + 1 \times \frac{100}{40} = 7.5 \text{ N}$

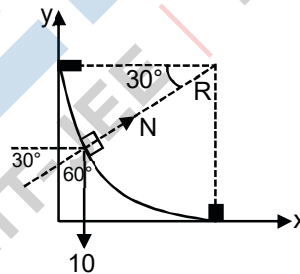

Paragraph for Questions 15 to 16

A thermal power plant produces electric power of 600 kW at 4000 V, which is to be transported to a place 20 km away from the power plant for consumers' usage. It can be transported either directly with a cable of large current carrying capacity or by using a combination of step-up and step-down transformers at the two ends. The drawback of the direct transmission is the large energy dissipation. In the method using transformers, the dissipation is much smaller. In this method, a step-up transformer is used at the plant side so that the current is reduced to a smaller value. At the consumer's end, a step-down transformer is used to supply power to the consumers at the specified lower voltage. It is reasonable to assume that the power cable is purely resistive and the transformers are ideal with a power factor unity. All the currents and voltages mentioned are rms values.

15. In the method using the transformers, assume that the ratio of the number of turns in the primary to that in the secondary in the step-up transformer is 1 : 10. If the power to the consumers has to be supplied at 200 V, the ratio of the number of turns in the primary to that in the secondary in the step-down transformer is
 (A*) 200 : 1 (B) 150 : 1 (C) 100 : 1 (D) 50 : 1

Ans. [A]

Sol. $\frac{\epsilon_p}{\epsilon_s} = \frac{N_p}{N_s} = \frac{1}{10}$

$\epsilon_s = 40,000 \text{ V}$

$\frac{\epsilon_p}{\epsilon_s} = \frac{N_p}{N_s}$

$\frac{40000}{200} = \frac{N_p}{N_s} \Rightarrow \frac{N_p}{N_s} = 200$

16. If the direct transmission method with a cable of resistance $0.4 \Omega \text{ km}^{-1}$ is used, the power dissipation (in %) during transmission is
 (A) 20 (B*) 30 (C) 40 (D) 50

Ans. [B]

Sol. $P = Vi$

$\Rightarrow i = \frac{600 \times 10^3}{4 \times 10^3} = 150 \text{ A}$

$P = i^2 R = 150^2 \times 0.4 \times 20$

$= \frac{P}{P_t} = \frac{150 \times 0.4 \times 20 \times 150}{600 \times 1000} = \frac{300}{1000} \times 100 = 30\%$

Section - III

(Matching List Type)

This section contains 4 multiple choice questions. Each question has matching lists. The codes for the lists have choices (A), (B), (C) and (D) out of which **ONLY ONE** is correct.

17. A right-angled prism of refractive index μ_1 is placed in a rectangular block of refractive index μ_2 , which is surrounded by a medium of refractive index μ_3 , as shown in the figure. A ray of light 'e' enters the rectangular block at normal incidence. Depending upon the relationships between μ_1 , μ_2 and μ_3 it takes one of the four possible paths 'ef', 'eg', 'eh' or 'ei'.

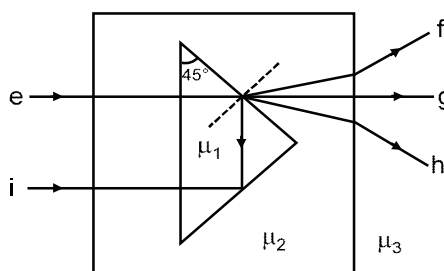

Match the paths in List I with conditions of refractive indices in List II and select the correct answer using the codes given below the lists :

List I

- P. e → f
- Q. e → g
- R. e → h
- S. e → i

List II

- 1. $\mu_1 > \sqrt{2} \mu_2$
- 2. $\mu_2 > \mu_1$ and $\mu_2 > \mu_3$
- 3. $\mu_1 = \mu_2$
- 4. $\mu_2 < \mu_1 < \mu_2$ and $\mu_2 > \mu_3$

Codes :

	P	Q	R	S
(A)	2	3	1	4
(C)	4	1	2	3

	P	Q	R	S
(B)	1	2	4	3
(D*)	2	3	4	1

Ans. [D]

Sol. $\mu_1 = \mu_2 \Rightarrow e \rightarrow g$
 $\ell \rightarrow h$

$\mu_2 > \mu_1$ {ray bends away from normal}

and $\mu_2 > \mu_3$ {ray bends away from normal}

TIR does not occur $\mu_1 < \sqrt{2} \mu_2$

TIR $\Rightarrow \mu_1 \sin 45^\circ > \mu_2 \sin 90^\circ$

$\mu_1 > \sqrt{2} \mu_2$

18. Match List I with II and select the correct answer using the codes given below the lists :

List I

- P. Boltzmann constant
- Q. Coefficient of viscosity
- R. Planck constant
- S. Thermal conductivity

List II

- 1. $[ML^2T^{-1}]$
- 2. $[ML^{-1}T^{-1}]$
- 3. $[MLT^{-3}K^{-1}]$
- 4. $[ML^2T^{-2}K^{-1}]$

Codes :

	P	Q	R	S
(A)	3	1	2	4
(B)	3	2	1	4
(C*)	4	2	1	3
(D)	4	1	2	3

Ans. [C]

Sol. $f : 6\pi\eta rV$

$$[\eta] = \frac{MLT^{-2}}{L^2T^{-1}} = ML^{-1}T^{-1}$$

$$[k] = ML^2T^{-2}K^{-1}$$

$$[h] = \left[\frac{E}{f} \right] = ML^2T^{-1}$$

$$[k] = \frac{\frac{dQ}{dt}}{\frac{A_T}{L}} = \frac{ML^2T^{-3}}{LK}$$

19. One mole of a monatomic ideal gas is taken along two cyclic processes $E \rightarrow F \rightarrow G \rightarrow E$ and $E \rightarrow F \rightarrow H \rightarrow E$ as shown in the PV diagram. The processes involved are purely isochoric, isobaric, isothermal or adiabatic.

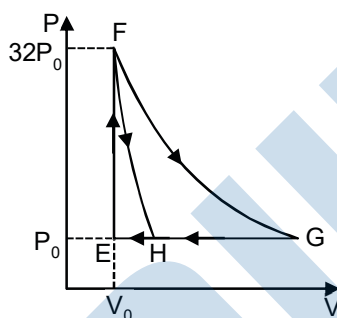

Match the paths in List I with the magnitudes of the work done in List II and select the correct answer using the codes given below the lists.

List I

- P. $G \rightarrow E$
- Q. $G \rightarrow H$
- R. $F \rightarrow H$
- S. $F \rightarrow G$

List II

- 1. $160 P_0 V_0 \ln 2$
- 2. $36 P_0 V_0$
- 3. $24 P_0 V_0$
- 4. $31 P_0 V_0$

Codes :

	P	Q	R	S		P	Q	R	S
(A*)	4	3	2	1	(B)	4	3	1	2
(C)	3	1	2	4	(D)	1	3	2	4

Ans. [A]

Sol. $F \rightarrow G \rightarrow$ isotherm $\rightarrow 160P_0V_0 \ln 2$

$$32 P_0 V_0^{5/3} = P_0 V^{5/3}$$

$$V_H = 8V_0$$

$$P_0 V_G = 32P_0 \times V_0$$

$$V_G = 32 V_0$$

$$W_{GE} = P_0 \times 31 V_0$$

$$W_{F-G} = 32P_0V_0 \ln \left(\frac{32V_0}{V_0} \right) = 160P_0V_0 \ln 2$$

20. Match List I of the nuclear processes with List II containing parent nucleus and one of the end products of each process and then select the correct answer using the codes given below the lists :

List I	List II
P. Alpha decay	1. ${}^{15}_8\text{O} \rightarrow {}^{15}_7\text{N} + \dots$
Q. β^+ decay	2. ${}^{238}_{92}\text{U} \rightarrow {}^{234}_{90}\text{Th} + \dots$
R. Fission	3. ${}^{185}_{83}\text{Bi} \rightarrow {}^{184}_{82}\text{Pb} + \dots$
S. Proton emission	4. ${}^{239}_{94}\text{Pu} \rightarrow {}^{140}_{57}\text{La} + \dots$

Codes :

	P	Q	R	S
(A)	4	2	1	3
(B)	1	3	2	4
(C*)	2	1	4	3
(D)	4	3	2	1

Ans. [C]

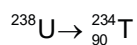
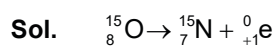

PART B : CHEMISTRY

Section - 1 :

(One or more options correct Type)

This section contains **8 multiple choice questions**. Each question has four choices (A), (B), (C) and (D) out of which **ONE or MORE** are correct.

21. In the nuclear transmutation :

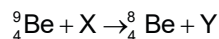

(X, Y) is(are)

(A*) (γ , n)

(B*) (p, D)

(C) (n, D)

(D) (γ , p)

Ans. [AB]

Sol. ${}^9_4\text{Be} \rightarrow {}^8_4\text{Be}$

Check from option

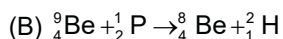
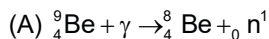

22. The correct statement(s) about O_3 is/are

(A*) O – O bond lengths are equal

(B) Thermal decomposition of O_3 is endothermic

(C*) O_3 is diamagnetic in nature

(D*) O_3 has a bent structure

Ans. [ACD]

Sol.

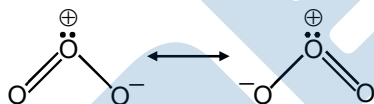

both bonds are equal due to resonance, central O-atom is sp^2 hybridised with $2\sigma + 1\ell, p$. in bent shape



So, $\text{O}_3 \rightarrow \text{O}_2 \quad \Delta H = -ve$ (exothermic)

23. The thermal dissociation equilibrium of $\text{CaCO}_3(\text{s})$ is studied under different conditions.



For this equilibrium, the correct statement(s) is(are)

(A*) ΔH is dependent on T

(B*) K is independent of the initial amount of CaCO_3

(C) K is dependent on the pressure of CO_2 at a given T

(D*) ΔH is independent of the catalyst, if any

Ans. [ABD]

Sol. $\text{CaCO}_3(\text{s}) \rightleftharpoons \text{CaO}(\text{s}) + \text{CO}_2(\text{g})$

(A) $\Delta H_{\text{T}_2} - \Delta H_{\text{T}_1} = \Delta(nC_p) dT$

$\Delta(nC_p) \neq 0$

\therefore [A] is true

(B) B is true since equilibrium constant is not dependent on amount of CaCO_3

(C) False at any give temperature K will be constant

(D) True

24. The carbon-based reduction method is **NOT** used for the extraction of

(A) tin from SnO_2

(B) iron from Fe_2O_3

(C*) aluminium from Al_2O_3

(D*) magnesium from $\text{MgCO}_3 \cdot \text{CaCO}_3$

Ans. [CD]

Sol. More electropositive metals like Al, Mg, Ca, Na are reduced by electrolytic reductions not by carbon reduction because they form carbides with them.

25. In the following reaction, the product(s) formed is(are)

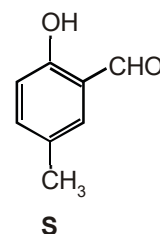
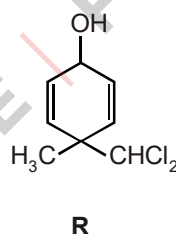
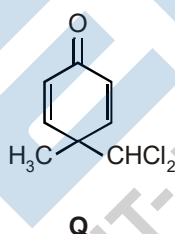
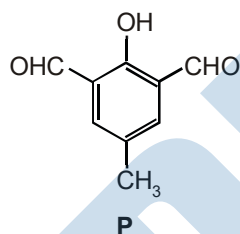
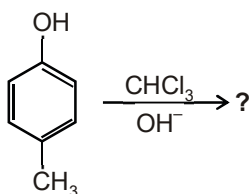

(A) P (Major)

(B*) Q (Minor)

(C) R (Minor)

(D*) S (Major)

Ans. [BD]

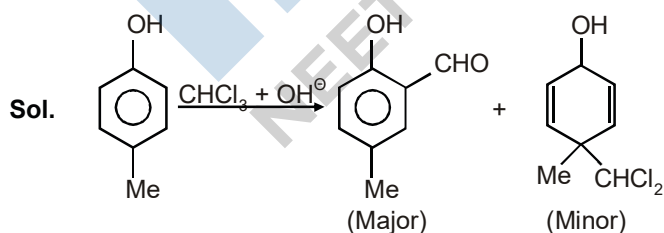

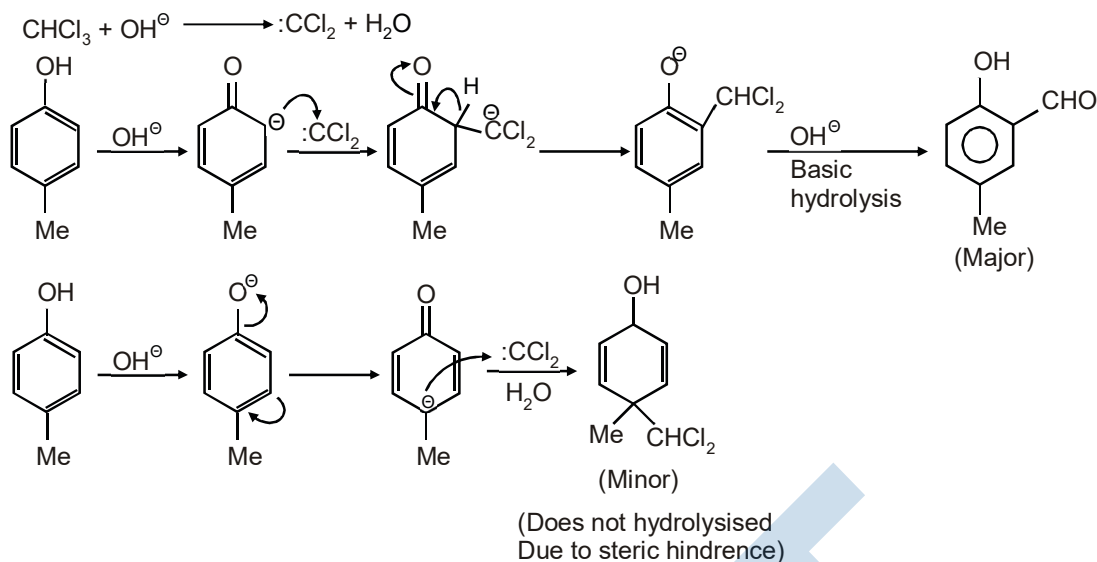

26. The K_{sp} of Ag_2CrO_4 is 1.1×10^{-12} at 298 K. the solubility (in mol/L) of Ag_2CrO_4 in a 0.1 M AgNO_3 solution is :

(A) 1.1×10^{-11} (B*) 1.1×10^{-10} (C) 1.1×10^{-12} (D) 1.1×10^{-9}

Ans. [B]

Sol. $(2S + 0.1)^2 \times S = 1.1 \times 10^{-12}$
 neglecting S as compared to 0.1
 $S = 1.1 \times 10^{-10}$

27. After completion of the reactions (I and II), the organic compound(s) in the reaction mixtures is(are):

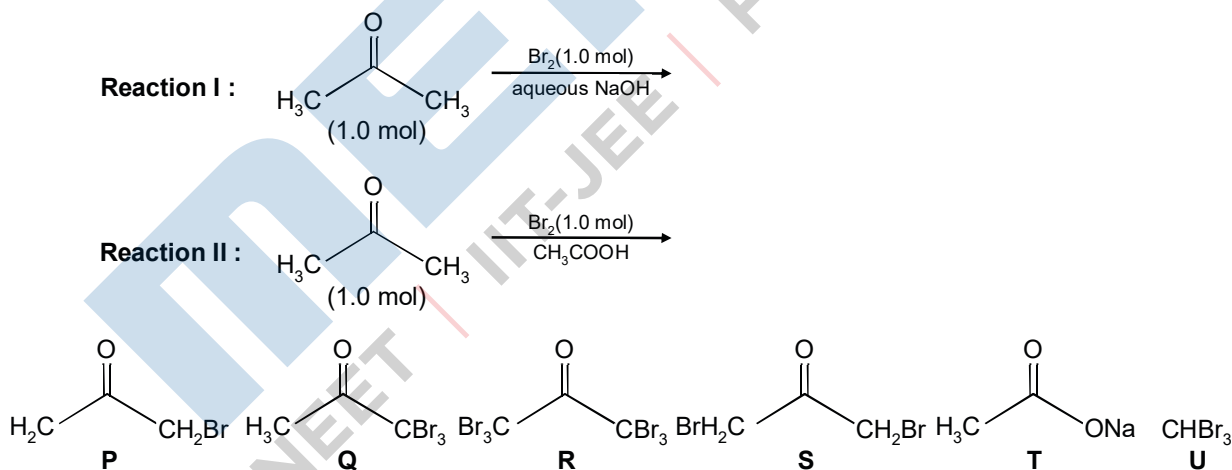

- (A) Reaction I : P and Reaction II : P
 (B) Reaction I : U, acetone and Reaction II : Q, acetone
 (C*) Reaction I : T, U, acetone and Reaction II : P
 (D) Reaction I : R, acetone and Reaction II : S, acetone

Ans. [C]

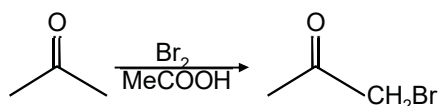
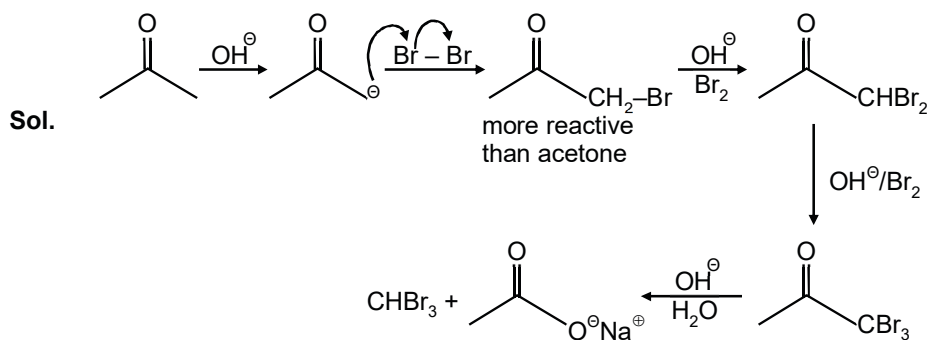

In acidic medium reaction takes place via enol form & enol of acetone is more reactive than enol of $\text{H}_3\text{C}-\text{C}(\text{O})-\text{CH}_2$ so that only monobromination take place at α -C.

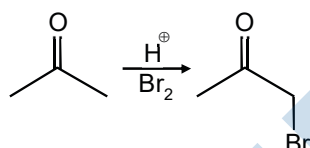
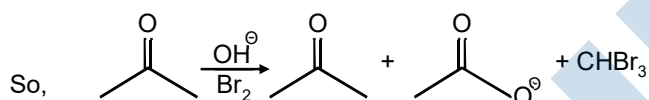

28. The major product(s) of the following reaction is(are)

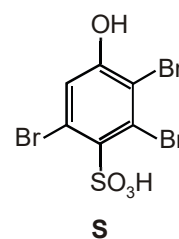
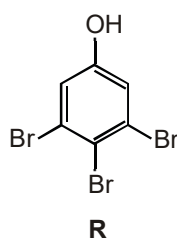
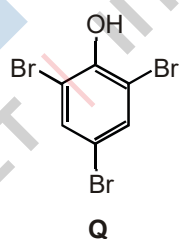
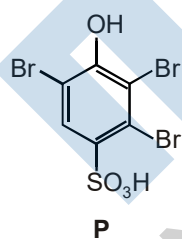
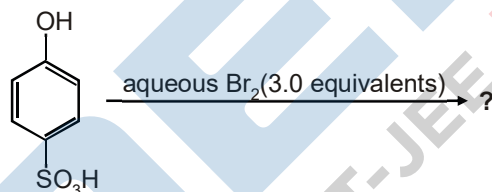

(A) P

(B*) Q

(C) R

(D) S

Ans. [B]

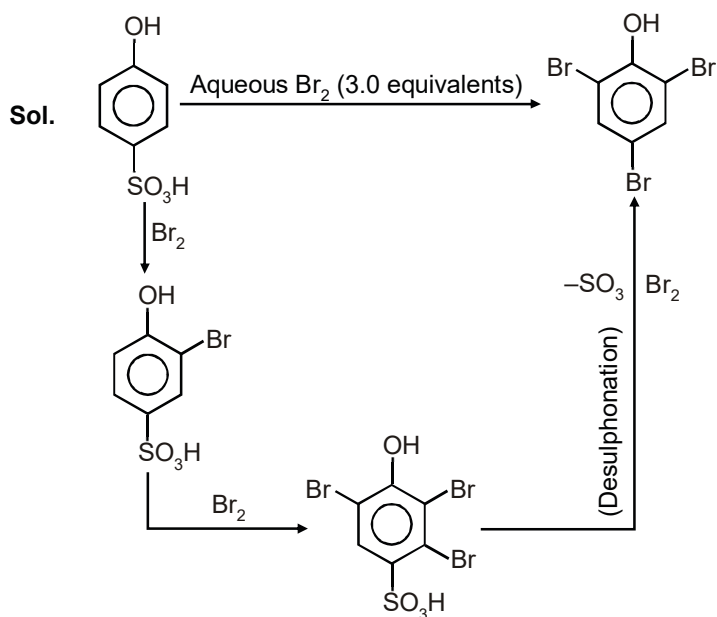

Section – II

(Paragraph Type)

This section contains **4 paragraphs** each describing theory, experiment, data etc. **Eight questions** relate to four paragraphs with two questions on each paragraph. Each questions of a paragraph has **only one correct answer** among the four choices (A), (B), (C) and (D).

Paragraph for question 29 and 30

A fixed mass 'm' of a gas is subjected to transformation of states from K to L to M to N and back to K as shown in the figure

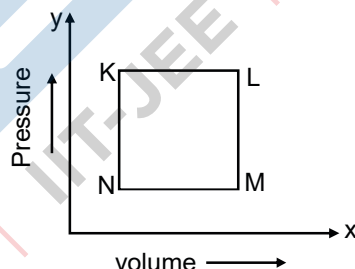

29. The pair of isochoric processes among the transformation of states is :

- (A) K to L and L to M
 (B*) L to M and N to K
 (C) L to M and M to N
 (D) M to N and N to K

Ans. [B]

Sol. (B) Volume constant in N to K and L to M

30. The succeeding operations that enable this transformation of states are :

- (A) Heating, cooling, heating, cooling
 (B) Cooling, heating, cooling, heating
 (C*) Heating, cooling, cooling, heating
 (D) Cooling, heating, heating, cooling

Ans. [C]

Sol. $K \rightarrow L$: ideal gas

P constant, n constant

V increases, temperature also increase

\therefore Heating Rejecting (B) and (D)

Checking M to N, P constant V decreases, n constant

Temperature decreases \therefore cooling

Paragraph for Questions 31 and 32

The reactions of Cl_2 gas with cold-dilute and hot-concentrated NaOH in water give sodium salts of two (different) oxoacids of chlorine, P and Q, respectively. The Cl_2 gas reacts with SO_2 gas, in presence of charcoal, to give a product R. R reacts with white phosphorus to give a compound S. On hydrolysis, S gives an oxoacid of phosphorus, T.

31. R, S and T, respectively, are

(A*) SO_2Cl_2 , PCl_5 and H_3PO_4

(B) SO_2Cl_2 , PCl_3 and H_3PO_3

(C) SOCl_2 , PCl_3 and H_3PO_2

(D) SOCl_2 , PCl_5 and H_3PO_4

Ans. [A]

32. P and Q, respectively, are the sodium salts of

(A*) hypochlorous and chloric acids

(B) hypochlorous and chlorous acids

(C) chloric and perchloric acids

(D) chloric and hypochlorous acids

Ans. [A]

Sol. $\text{Cl}_2 + \text{cold dil NaOH} \longrightarrow \text{NaCl} + \text{NaOCl}$ (P)

$\text{Cl}_2 + \text{hot conc. NaOH} \longrightarrow \text{NaCl} + \text{NaClO}_3$ (Q)

NaOCl is salt of hypochlorous acid

NaClO_3 is salt of chloric acid

$\text{Cl}_2 + \text{SO}_2 \longrightarrow \text{SO}_2\text{Cl}_2$ (R)

$5\text{SO}_2\text{Cl}_2 + 5\text{P}_4 \longrightarrow 2\text{PCl}_5$ (S) + 5SO_2

$\text{PCl}_5 + 4\text{H}_2\text{O} \longrightarrow \text{H}_3\text{PO}_4$ (T) + 5HCl

Paragraph for Questions 33 and 34

An aqueous solution of a mixture of two inorganic salts, when treated with dilute HCl , gave a precipitate (P) and a filtrate (Q). The precipitate P was found to dissolve in hot water. The filtrate (Q) remained unchanged, when treated with H_2S in a dilute mineral acid medium. However, it gave a precipitate (R) with H_2S in an ammoniacal medium. The precipitate R gave a coloured solution (S), when treated with H_2O_2 in an aqueous NaOH medium.

33. The coloured solution S contains

- (A) $\text{Fe}_2(\text{SO}_4)_3$ (B) CuSO_4 (C) ZnSO_4 (D*) Na_2CrO_4

Ans. [D]

34. The precipitate P contains

- (A*) Pb^{2+} (B) Hg_2^{2+} (C) Ag^+ (D) Hg^{2+}

Ans. [A]

Sol. \Rightarrow Pb^{2+} gives ppt. with dil HCl, which is soluble in hot water among Pb^{2+} , Hg_2^{2+} , Ag^+ , Hg^{2+} , Pb^{2+} also give ppt. with dil H^+ / H_2S .

\Rightarrow Cr^{3+} does not give ppt with dil. HCl, also does not give ppt. with H^+ / H_2S but gives coloured ppt. with OH^- / H_2S of green coloured $\text{Cr}(\text{OH})_3$, which is soluble in NaOH on reacting with H_2O_2 gives yellow coloured solution of Na_2CrO_4 .

Paragraph for Questions 35 and 36

P and Q are isomers of dicarboxylic acid $\text{C}_4\text{H}_4\text{O}_4$. Both decolorize $\text{Br}_2/\text{H}_2\text{O}$. On heating, P forms the cyclic anhydride.

Upon treatment with dilute alkaline KMnO_4 , P as well as Q could produce one or more than one from S, T and U.

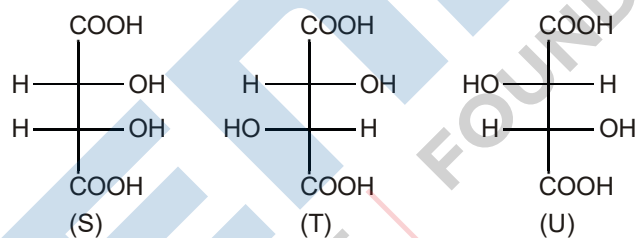

35. In the following reaction sequences V and W are respectively

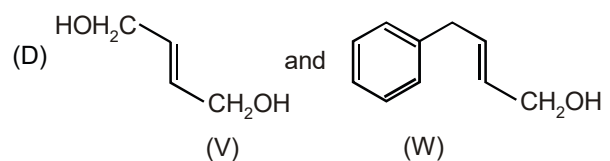
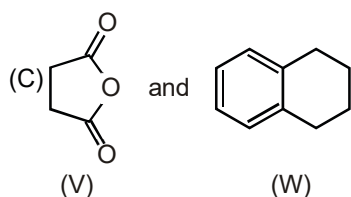
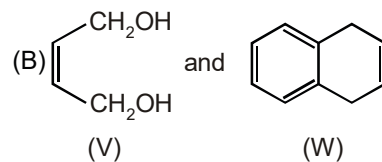
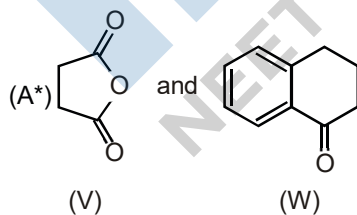
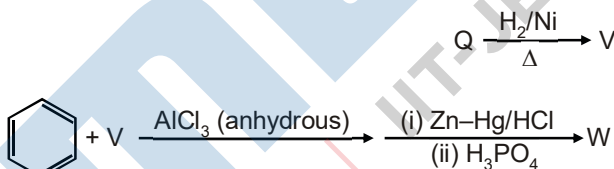

Ans. [A]

Sol. $C_4H_4O_4$

DU = 3

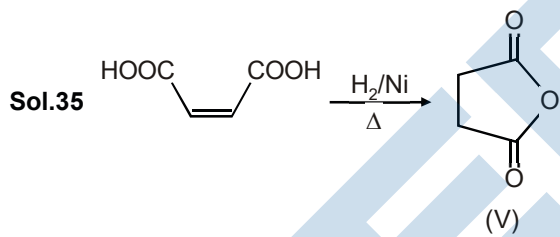
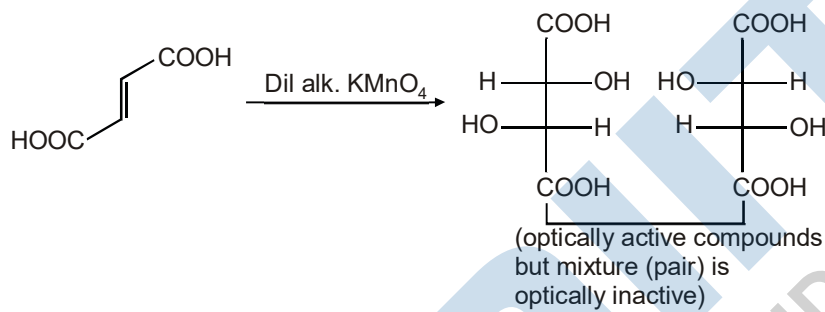
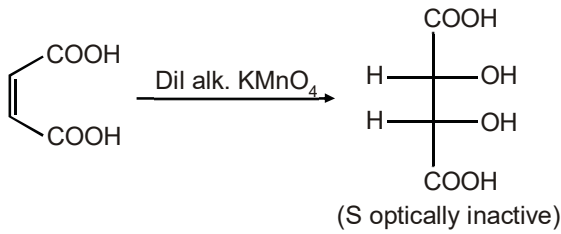
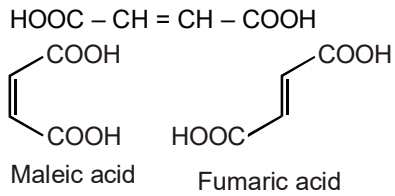

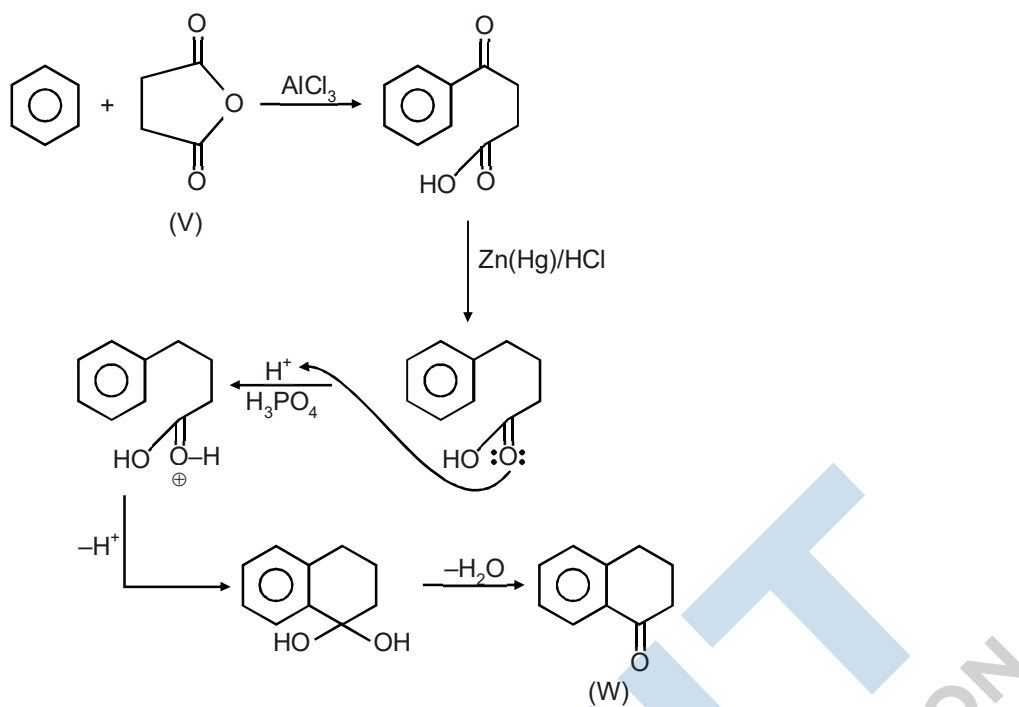

36. Compounds formed from P and Q are, respectively
- (A) Optically active S and optically active pair (T, U)
 - (B*) Optically inactive S and optically inactive pair (T, U)
 - (C) Optically active pair (T, U) and optically active S
 - (D) Optically inactive pair (T, U) and optically inactive S.

Ans. [B]

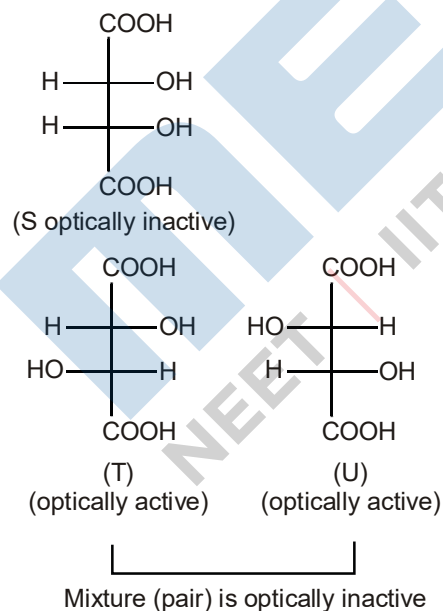

Sol.

Section - III

(Matching List Type)

This section contains **4 multiple choice questions**. Each question has matching lists. The codes for the lists have choices (A), (B), (C) and (D) out of which **ONLY ONE** is correct.

37. The unbalanced chemical reactions given in List I show missing reagent or condition (?) which are provided in List II. Match List I with List II and select the correct answer using the code given below the lists:

List I		List II	
(P)	$\text{PbO}_2 + \text{H}_2\text{SO}_4 \xrightarrow{?} \text{PbSO}_4 + \text{O}_2 + \text{other product}$	(1)	NO
(Q)	$\text{Na}_2\text{S}_2\text{O}_3 + \text{H}_2\text{O} \xrightarrow{?} \text{NaHSO}_4 + \text{other product}$	(2)	I_2
(R)	$\text{N}_2\text{H}_4 \xrightarrow{?} \text{N}_2 + \text{other product}$	(3)	Warm
(S)	$\text{XeF}_2 \xrightarrow{?} \text{Xe} + \text{other product}$	(4)	Cl_2



Codes:

	P	Q	R	S
(A)	4	2	3	1
(B)	3	2	1	4
(C)	1	4	2	3
(D*)	3	4	2	1

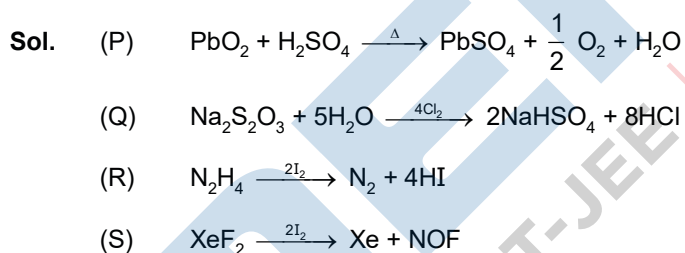
Ans. [D]

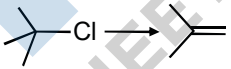

38. Match the chemical conversions in List I with the appropriate reagents in List II and select the correct answer using the code given below the lists:

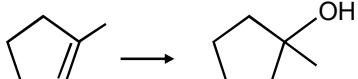
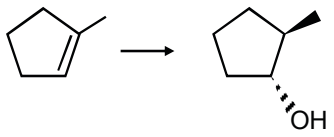
List I		List II	
(P)		(1)	(i) $\text{Hg}(\text{OAc})_2$; (ii) NaBH_4
(Q)		(2)	NaOEt
(R)		(3)	Et - Br
(S)		(4)	(i) BH_3 ; (ii) $\text{H}_2\text{O}_2/\text{NaOH}$

Codes :

	P	Q	R	S
(A*)	2	3	1	4
(B)	3	2	1	4
(C)	2	3	4	1
(D)	3	2	4	1

Ans. [A]

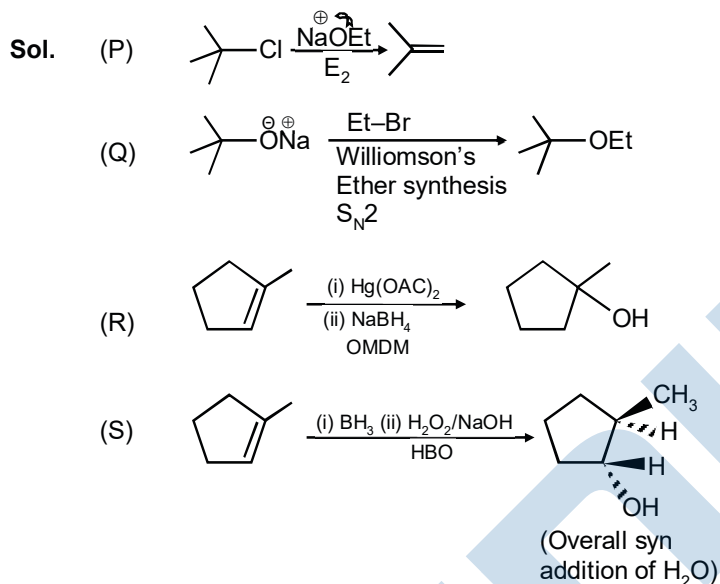

39. An aqueous solution of X is added slowly to an aqueous solution of Y as shown in List I. The variation in conductivity of these reactions is given in List II. Match List I with List II and select the correct using the code given below the lists:

List I

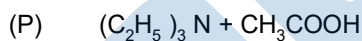

X Y

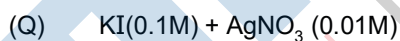

X Y



X Y

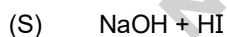

X Y

List II

(1) Conductivity decreases and then increases

(2) Conductivity decreases and then does not change much

(3) Conductivity increases and then does not change much

(4) Conductivity does not change much and then increases

Codes:

	P	Q	R	S
(A*)	3	4	2	1
(B)	4	3	2	1

(C) 2 3 4 1

(D) 1 4 3 2

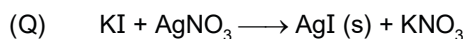
Ans [A]**Sol.** Checking easiest options Q and R**X Y**

On adding KI to AgNO_3 solution, Ag^+ is replaced by K^+ as Ag^+ and K^+ have approximately same conductivity so conductivity does not change much upto equivalence point after which on adding KI conductivity increases.

**X Y**

On adding CH_3COOH to KOH solution OH^- is replaced by CH_3COO^- so conductivity decreases upto equivalence point after which on adding CH_3COOH further conductivity does not change much as CH_3COOH is a weak acid (also in the presence of common ion dissociation of CH_3COOH will be quite lesser)

40. The standard reduction potential data at 25°C is given below.

$$E^\circ (\text{Fe}^{3+}, \text{Fe}^{2+}) = +0.77 \text{ V};$$

$$E^\circ (\text{Fe}^{2+}, \text{Fe}) = -0.44 \text{ V}$$

$$E^\circ (\text{Cu}^{2+}, \text{Cu}) = +0.34 \text{ V};$$

$$E^\circ (\text{Cu}^+, \text{Cu}) = +0.52 \text{ V}$$

$$E^\circ [\text{O}_2(\text{g}) + 4\text{H}^+ + 4\text{e}^- \rightarrow 2\text{H}_2\text{O}] = +1.23 \text{ V};$$

$$E^\circ [\text{O}_2(\text{g}) + 2\text{H}_2\text{O} + 4\text{e}^- \rightarrow 4\text{OH}^-] = +0.40 \text{ V}$$

$$E^\circ (\text{Cr}^{3+}, \text{Cr}) = -0.74 \text{ V};$$

$$E^\circ (\text{Cr}^{2+}, \text{Cr}) = -0.91 \text{ V}$$

Match E° of the redox pair in List I with the values given in List II and select the correct answer using the code given below the lists:

List I	List II
(P) $E^\circ (\text{Fe}^{3+}, \text{Fe})$	(1) -0.18 V
(Q) $E^\circ (4\text{H}_2\text{O} / 4\text{H}^+ + 4\text{OH}^-)$	(2) -0.4 V
(R) $E^\circ (\text{Cu}^{2+} + \text{Cu} \rightarrow 2\text{Cu}^+)$	(3) -0.04 V
(S) $E^\circ (\text{Cr}^{3+}, \text{Cr}^{2+})$	(4) -0.83 V

PART C : MATHEMATICS

Section - 1 :

(One or more options correct Type)

This section contains **8 multiple choice questions**. Each question has four choices (A), (B), (C) and (D) out of which **ONE or MORE** are correct.

41. If $3^x = 4^{x-1}$, then $x =$

- (A*) $\frac{2\log_3 2}{2\log_3 2 - 1}$ (B*) $\frac{2}{2 - \log_2 3}$ (C*) $\frac{1}{1 - \log_4 3}$ (D) $\frac{2\log_2 3}{2\log_2 3 - 1}$

Ans. [ABC]

Sol. $3^x = 4^{x-1}$

$$\begin{aligned} \Rightarrow \log_3 3^x &= \log_3 4^{(x-1)} &\Rightarrow x &= (x-1)\log_3 4 &\Rightarrow x &= 2(x-1)\log_3 2 \\ \Rightarrow 2\log_3 2 &= x(2\log_3 2 - 1) \\ \Rightarrow x &= \frac{2\log_3 2}{2\log_3 2 - 1} = \frac{2}{2 - \log_2 3} = \frac{1}{1 - \frac{1}{2}\log_2 3} = \frac{1}{1 - \log_{2^2} 3} \end{aligned}$$

42. Let $w = \frac{\sqrt{3}+i}{2}$ and $P = \{w^n : n = 1, 2, 3, \dots\}$. Further $H_1 = \left\{z \in \mathbb{C} : \operatorname{Re} z > \frac{1}{2}\right\}$ and $H_2 = \left\{z \in \mathbb{C} : \operatorname{Re} z < \frac{-1}{2}\right\}$, where \mathbb{C} is the set of all complex numbers. If $z_1 \in P \cap H_1$, $z_2 \in P \cap H_2$ and O represents the origin, then $\angle z_1 O z_2 =$

- (A) $\frac{\pi}{2}$ (B) $\frac{\pi}{6}$ (C*) $\frac{2\pi}{3}$ (D*) $\frac{5\pi}{6}$

Ans. [CD]

Sol.

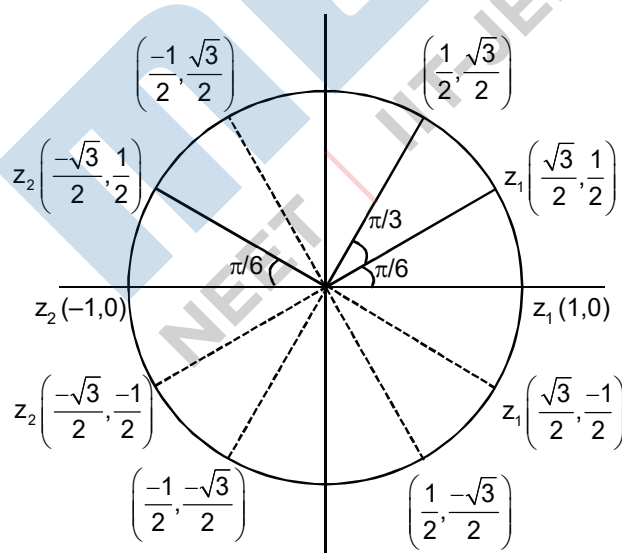

$$w = \frac{\sqrt{3} + i}{2} = \cos \frac{\pi}{6} + i \sin \frac{\pi}{6}$$

$$P = w^n = \cos \frac{n\pi}{6} + i \sin \frac{n\pi}{6}, n = 0, 1, 2, \dots, 11.$$

$$H_1 = \left\{ z \in \mathbb{C} : \operatorname{Re}(z) > \frac{1}{2} \right\}$$

$$z_1 \in P \cap H_1$$

$$\therefore \text{possible value of } z_1 \text{ are } \left\{ \left(\frac{\sqrt{3}}{2}, \frac{1}{2} \right), (0, 1), \left(\frac{\sqrt{3}}{2}, -\frac{1}{2} \right) \right\}$$

$$H_2 = \left\{ z \in \mathbb{C} : \operatorname{Re}(z) < -\frac{1}{2} \right\}$$

$$z_2 \in P \cap H_2$$

$$\therefore \text{possible values of } z_2 \text{ are } \left\{ \left(-\frac{\sqrt{3}}{2}, \frac{1}{2} \right), (-1, 0), \left(-\frac{\sqrt{3}}{2}, -\frac{1}{2} \right) \right\}$$

$$\text{Now, possible angle } z_1 O z_2 \text{ is } = \frac{2\pi}{3}, \frac{5\pi}{6}, \pi$$

43. The function $f(x) = 2|x| + |x+2| - |x+2| - 2|x|$ has a local minimum or a local maximum at $x =$

(A*) -2 (B*) $-\frac{2}{3}$ (C) 2 (D) $\frac{2}{3}$

Ans. [AB]

Sol. $x > 0$

$$f(x) = 2x + x + 2 - |2 - x|$$

$$x \geq 2$$

$$2x + x + 2 - x + 2 = 2x + 4$$

$$0 \leq x < 2$$

$$2x + x + 2 - 2 + x = 4x$$

$$x \leq -2$$

$$f(x) = -2x - x - 2 - |-x - 2 + 2x|$$

$$= -3x - 2 - |x - 2|$$

$$= -3x - 2 + x - 2 = -2x - 4$$

$$-2 < x < 0$$

$$f(x) = -2x + x + 2 - |x + 2 + 2x|$$

$$= -2x + x + 2 - |3x + 2|$$

$$-2 < x < -\frac{2}{3}$$

$$-\frac{2}{3} < x < 0$$

$$-2x + x + 2 + 3x + 2$$

$$-2x + x + 2 - 3x - 2$$

$$2x + 4$$

$$-4x$$

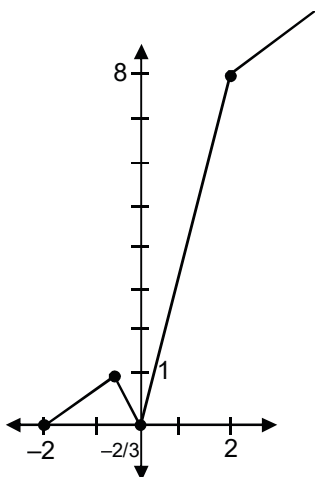

44. Let ω be a complex cube root of unity with $\omega \neq 1$ and $P = [p_{ij}]$ be a $n \times n$ matrix with $p_{ij} = \omega^{ij}$. Then $P^2 \neq 0$, when $n =$
- (A) 57 (B*) 55 (C*) 58 (D*) 56

Ans. [BCD]

Sol.
$$P = \begin{bmatrix} \omega^2 & \omega^3 & \omega^4 & \dots & \omega^{n+1} \\ \omega^3 & \omega^4 & & & \\ \omega^4 & & & & \\ \vdots & & & & \\ \omega^{n+1} & & & & \omega^{2n} \end{bmatrix}$$

$$P^2 = \begin{bmatrix} \omega^2 & \omega^3 & \dots & \omega^{n+1} \\ \omega^3 & \omega^4 & \dots & \dots \\ \vdots & \vdots & \dots & \dots \\ \omega^{n+1} & \omega^{n+2} & \dots & \omega^{2n} \end{bmatrix} \begin{bmatrix} \omega^2 & \omega^3 & \dots & \omega^{n+1} \\ \omega^3 & \dots & \dots & \dots \\ \vdots & \vdots & \dots & \dots \\ \omega^{n+1} & \dots & \dots & \omega^{2n} \end{bmatrix} = \begin{bmatrix} \omega^4 + \omega^6 + \omega^8 + \dots + \omega^{2n+2} & \dots \\ \vdots & \dots \\ \vdots & \dots \end{bmatrix}$$

for null matrix

$\omega^4 + \omega^6 + \omega^8 + \dots + \omega^{2n+2}$ must be zero

and in this case each elements and matrix P^2 will be zero

so $\omega^4 + \omega^6 + \omega^8 + \dots + \omega^{2n+2}$ have n terms(i)

and $\omega^4 + \omega^6 + \omega^8 = \omega + 1 + \omega^2 = 0$

$\omega^{10} + \omega^{12} + \omega^{14} = 0$

i.e. ω^{2n+2} must gives $\omega^{2n} \cdot \omega^2$

(Last term each triplets in ω^2)

$\therefore 2n = 3k$ (k is an integer)

$\therefore n$ must be divisible by 3 for P^2 to be null matrix

$\therefore n = 57$

\therefore Answer is **B, C, D**

45. Circle(s) touching x-axis at a distance 3 from the origin and having an intercept of length $2\sqrt{7}$ on y-axis is(are)

(A*) $x^2 + y^2 - 6x + 8y + 9 = 0$

(B) $x^2 + y^2 - 6x + 7y + 9 = 0$

(C*) $x^2 + y^2 - 6x - 8y + 9 = 0$

(D) $x^2 + y^2 - 6x - 7y + 9 = 0$

Ans. [AC]

Sol. Let the equation of circle be

$$(x - 3)^2 + (y - 0)^2 + \lambda(y) = 0 \begin{matrix} y_1 \\ y_2 \end{matrix}$$

Put $x = 0$

$$\Rightarrow y^2 + \lambda y + 9 = 0$$

$$\therefore |y_1 - y_2| = 2\sqrt{7}$$

$$\Rightarrow (\lambda)^2 - 36 = 28 \Rightarrow \lambda^2 = 64 \Rightarrow \lambda = \pm 8$$

So, equation of circles is $x^2 + y^2 - 6x \pm 8y + 9 = 0$

Similarly, equation of other circle will be

$$x^2 + y^2 + 6x \pm 8y + 9 = 0.$$

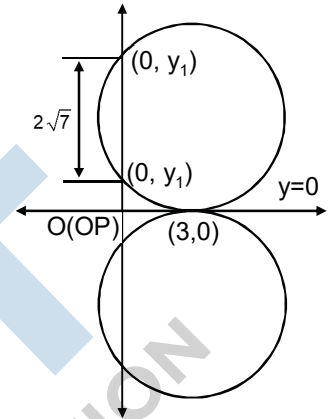

46. For $a \in \mathbb{R}$ (the set of all real numbers), $a \neq -1$

$$\lim_{n \rightarrow \infty} \frac{(1^a + 2^a + \dots + n^a)}{(n+1)^{a-1} [(na+1) + (na+2) + \dots + (na+n)]} = \frac{1}{60}. \text{ Then } a =$$

(A) 5

(B*) 7

(C) $-\frac{15}{2}$

(D*) $-\frac{17}{2}$

Ans. [BD]

Sol.
$$\lim_{n \rightarrow \infty} \frac{n^a \left[\left(\frac{1}{n}\right)^a + \left(\frac{2}{n}\right)^a + \dots + \left(\frac{n}{n}\right)^a \right]}{n^a \left(1 + \frac{1}{n}\right)^{a-1} \left[\left(n + \frac{1}{a}\right) + \left(n + \frac{2}{a}\right) + \dots + \left(n + \frac{n}{a}\right) \right]} = \frac{1}{60}$$

$$\Rightarrow \lim_{n \rightarrow \infty} \frac{\sum_{r=1}^n \left(\frac{r}{n}\right)^a \cdot \frac{1}{n}}{\sum_{r=1}^n \left(n + \frac{r}{a}\right) \cdot \frac{1}{n}} = \frac{1}{60} \Rightarrow \frac{\int_0^1 x^a dx}{\int_0^1 (n+x) dx} = \frac{1}{60} \Rightarrow \frac{\frac{1}{(a+1)} [x^{a+1}]_0^1}{\left[nx + \frac{x^2}{2} \right]_0^1} = \frac{1}{60}$$

$\therefore a = 7$ and $b = -\frac{17}{2}$. Ans.

47. In a triangle PQR, P is the largest angle and $\cos P = \frac{1}{3}$. Further the incircle of the triangle touches the sides PQ, QR and RP at N, L and M respectively, such that the lengths of PN, QL and RM are consecutive even integers. Then possible length(s) of the side(s) of the triangle is(are)

(A) 16

(B*) 18

(C) 24

(D*) 22

Ans. [BD]

Sol. $\cos p = \frac{1}{3} = \frac{(4n + 2)^2 + (4n + 4)^2 - (4n + 6)^2}{2(4n + 2)(4n + 4)}$

$$\frac{1}{3} = \frac{16(n^2 - 1)}{16(2n + 1)(n + 1)}$$

$$\Rightarrow (2n + 1)(n + 1) = 3n^2 = 3$$

$$\Rightarrow n^2 - 3n - 4 = 0$$

$$\Rightarrow (n - 4)(n + 1) = 0$$

$$\therefore n = 4$$

$$\therefore n = 4$$

So sides are 18, 20, 22

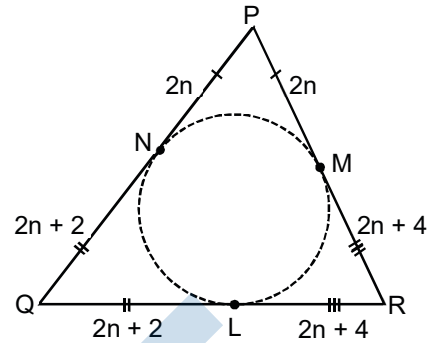

48. Two lines $L_1 : x = 5, \frac{y}{3 - \alpha} = \frac{z}{-2}$ and $L_2 : x = \alpha, \frac{y}{-1} = \frac{z}{2 - \alpha}$ are coplanar. Then α can take value(s)

(A*) 1

(B) 2

(C) 3

(D*) 4

Ans. [AD]

Sol. $L_1 : \frac{x - 5}{0} = \frac{y - 0}{3 - \alpha} = \frac{z - 0}{-2}$

$$L_2 : \frac{x - \alpha}{0} = \frac{y - 0}{-1} = \frac{z - 0}{2 - \alpha}$$

As L_1 and L_2 are coplanar, so $\begin{vmatrix} 5 - \alpha & 0 & 0 \\ 0 & 3 - \alpha & -2 \\ 0 & -1 & 2 - \alpha \end{vmatrix} = 0$

$$\Rightarrow -(\alpha - 5)[(\alpha - 3)(\alpha - 2) - 2] = 0$$

$$\Rightarrow -(\alpha - 5)[\alpha^2 - 5\alpha + 4] = 0$$

$$\Rightarrow (\alpha - 5)(\alpha - 1)(\alpha - 4) = 0$$

$$\Rightarrow \alpha = 1, 4, 5$$

Section - II

(Paragraph Type)

This section contains **4 paragraphs** each describing theory, experiment, data etc. **Eight questions** relate to four paragraphs with two questions on each paragraph. Each questions of a paragraph has **only one correct answer** among the four choices (A), (B), (C) and (D).

Paragraph for Questions 49 and 50

Let $S = S_1 \cap S_2 \cap S_3$, where

$$S_1 = \{z \in \mathbb{C} : |z| < 4\}, S_2 = \text{and } S_3 = \{z \in \mathbb{C} : \text{Re } z > 0\}.$$

49. $\text{Min}_{z \in S} |1 - 3i - z| =$

(A) $\frac{2 - \sqrt{3}}{2}$

(B) $\frac{2 + \sqrt{3}}{2}$

(C*) $\frac{3 - \sqrt{3}}{2}$

(D) $\frac{3 + \sqrt{3}}{2}$

Ans. [C]

Q.50 Area of S =

- (A) $\frac{10\pi}{3}$ (B*) $\frac{20\pi}{3}$ (C) $\frac{16\pi}{3}$ (D) $\frac{32\pi}{3}$

Ans. [B]

Sol. $S_1: x^2 + y^2 < 16$

$$S_2: \operatorname{Im}\left(\frac{(z-1+\sqrt{3}i)(1+\sqrt{3}i)}{4}\right) > 0$$

$$\text{or } \operatorname{Im}\left(\frac{\{z-(1-\sqrt{3}i)\}\{1+\sqrt{3}i\}}{4}\right) > 0$$

$$\text{or } \operatorname{Im}\left(\frac{(1+\sqrt{3}i)z-4}{4}\right) > 0 \Rightarrow \sqrt{3}x + y > 0$$

$S_3: x > 0$

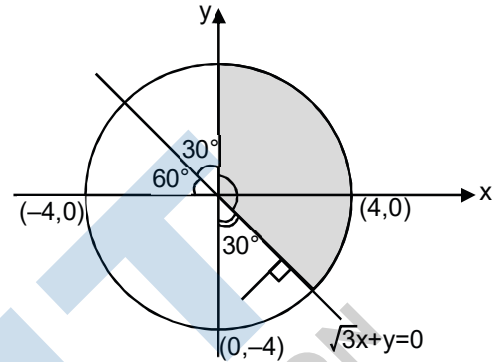

(i) $|1 - 3i - z| = |z - 1 + 3i| = |z - (1 - 3i)|$

$$\text{Distance between } [z \text{ and } (1, -3)] = \left| \frac{\sqrt{3}-3}{\sqrt{3}+1} \right| = \frac{3-\sqrt{3}}{\sqrt{3}+1}$$

(ii) Area of S = $\frac{1}{2} \times 16 \times \frac{5\pi}{6} = \frac{20\pi}{3}$ sq. unit

Paragraph for Questions 51 and 52

A box B_1 contains 1 white ball, 3 red balls and 2 black balls. Another box B_2 contains 2 white balls, 3 red balls and 4 black balls. A third box B_3 contains 3 white balls, 4 red balls and 5 black balls.

51. If 2 balls are drawn (without replacement) from a randomly selected box and one of the balls is white and the other ball is red, the probability that these 2 balls are drawn from box B_2 is

- (A) $\frac{116}{181}$ (B) $\frac{126}{181}$ (C) $\frac{65}{181}$ (D*) $\frac{55}{181}$

Ans. [D]

52. If 1 ball is drawn from each of the boxes B_1, B_2 and B_3 , the probability that all 3 drawn balls are of the same colour is

- (A*) $\frac{82}{648}$ (B) $\frac{90}{648}$ (C) $\frac{558}{648}$ (D) $\frac{566}{648}$

Ans. [A]

Sol. $B_1 \begin{cases} 1 W \\ 3 R \\ 2 B \\ \hline 6 \end{cases}; B_2 \begin{cases} 2 W \\ 3 R \\ 4 B \\ \hline 9 \end{cases} \text{ and } B_3 \begin{cases} 3 W \\ 4 R \\ 5 B \\ \hline 12 \end{cases}$

(i) Probability = $\frac{\frac{1}{3} \times \left(\frac{{}^2C_1 \times {}^3C_1}{{}^9C_2} \right)}{\frac{1}{3} \times \left[\frac{{}^1C_1 \times {}^3C_1}{{}^6C_2} + \frac{{}^2C_1 \times {}^3C_1}{{}^9C_2} + \frac{{}^3C_1 \times {}^4C_1}{{}^{12}C_2} \right]} = \frac{\frac{6}{36}}{\frac{13}{15} + \frac{6}{30} + \frac{12}{66}} = \frac{\frac{1}{6}}{\frac{1}{5} + \frac{1}{6} + \frac{2}{11}} = \frac{55}{181}$. **Ans.**

(ii) Probability = $\left(\frac{1}{6} \times \frac{2}{9} \times \frac{3}{12} \right) + \left(\frac{3}{6} \times \frac{3}{9} \times \frac{4}{12} \right) = \frac{6 + 36 + 40}{72 \times 9} = \frac{82}{648}$. **Ans.**

Paragraph for Questions 53 and 54

Let $f : [0, 1] \rightarrow \mathbb{R}$ (the set of all real numbers) be a function. Suppose the function f is twice differentiable, $f(0) = f(1) = 0$ and satisfies $f''(x) - 2f'(x) + f(x) \geq e^x$, $x \in [0, 1]$.

53. If the function $e^{-x} f(x)$ assumes its minimum in the interval $[0, 1]$ at $x = \frac{1}{4}$, which of the following is true?

- (A) $f'(x) < f(x)$, $\frac{1}{4} < x < \frac{3}{4}$ (B) $f'(x) > f(x)$, $0 < x < \frac{1}{4}$
 (C*) $f'(x) < f(x)$, $0 < x < \frac{1}{4}$ (D) $f'(x) < f(x)$, $\frac{3}{4} < x < 1$

Ans. [C]

54. Which of the following is true for $0 < x < 1$?

- (A) $0 < f(x) < \infty$ (B) $-\frac{1}{2} < f(x) < \frac{1}{2}$ (C) $-\frac{1}{4} < f(x) < 1$ (D*) $-\infty < f(x) < 0$

Ans. [D]

Sol.

53. $\frac{d}{dx} [e^{-x} f(x)] < 0 \forall x \in \left(0, \frac{1}{4}\right)$
 $\Rightarrow e^{-x} [f'(x) - f(x)] < 0 \quad \forall x \in \left(0, \frac{1}{4}\right)$
 $\Rightarrow f'(x) - f(x) < 0$

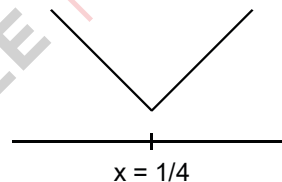

54. $f''(x) - 2f'(x) + f(x) \geq e^x$

$e^{-x} (f''(x) - 2f'(x) + f(x)) \geq 1$

$\Rightarrow \frac{d^2}{dx^2} (e^{-x} f(x)) \geq 1$

\therefore second order derivative of $e^{-x} f(x)$ is positive

\Rightarrow graph of $e^{-x} f(x)$ is concave upwards

$\Rightarrow f(x) < 0$ in $(0, 1)$

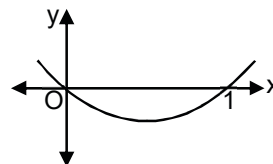

Paragraph for Questions 55 and 56

Let PQ be a focal chord of the parabola $y^2 = 4ax$. The tangents to the parabola at P and Q meet at a point lying on the line $y = 2x + a$, $a > 0$.

55. If chord PQ subtends an angle θ at the vertex of $y^2 = 4ax$, then $\tan \theta =$

- (A) $\frac{2\sqrt{7}}{3}$ (B) $\frac{-2\sqrt{7}}{3}$ (C) $\frac{2\sqrt{5}}{3}$ (D*) $\frac{-2\sqrt{5}}{3}$

Ans. [D]

56. Length of chord PQ is

- (A) $7a$ (B*) $5a$ (C) $2a$ (D) $3a$

Ans. [B]

Sol.

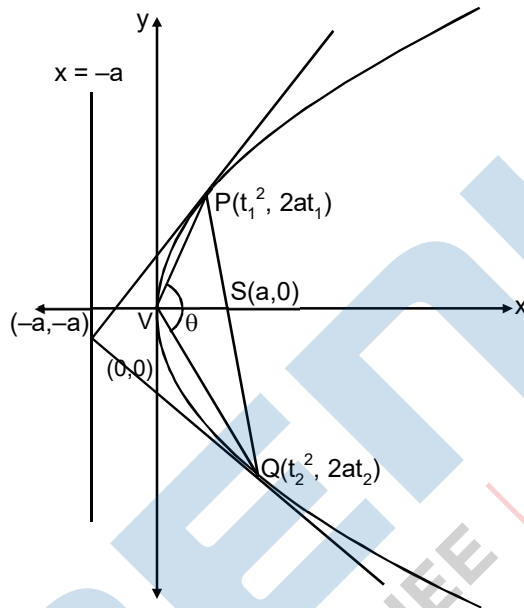

Here, $t_1 t_2 = -1$
and $t_1 + t_2 = -1$

(i) Here $\theta =$ obtuse angle

$\therefore \tan \theta < 0$

Now, $|\tan \theta| = \left| \frac{\frac{2}{t_1} - \frac{2}{t_2}}{1 + \frac{t_1}{t_2}} \right| = \frac{2}{3}\sqrt{5} \Rightarrow \tan \theta = \frac{-2}{3}\sqrt{5}$

(ii) Length PQ

$= (a + at_1^2) + (a + at_2^2)$
 $= a[t_1^2 + t_2^2 + 2]$
 $= a[(t_1 + t_2)^2 - 2t_1 t_2 + 2]$

\therefore Length PQ = $5a$ Ans.

Section - III

(Matching List Type)

This section contains 4 multiple choice questions. Each question has matching lists. The codes for the lists have choices (A), (B), (C) and (D) out of which **ONLY ONE** is correct.

57. Match List-I with List-II and select the correct answer using the code given below the lists:

- | List I | List II |
|--|------------------------------------|
| P. $\left(\frac{1}{y^2} \left(\frac{\cos(\tan^{-1} y) + y \sin(\tan^{-1} y)}{\cot(\sin^{-1} y) + \tan(\sin^{-1} y)} \right)^2 + y^4 \right)^{\frac{1}{2}}$ takes value | 1. $\frac{1}{2}\sqrt{\frac{5}{3}}$ |
| Q. If $\cos x + \cos y + \cos z = 0 = \sin x + \sin y + \sin z$ then possible value of $\cos\left(\frac{x-y}{2}\right)$, is | 2. $\sqrt{2}$ |
| R. If $\cos\left(\frac{\pi}{4} - x\right) \cos 2x + \sin x \sin 2x \sec x = \cos x \sin 2x \sec x + \cos\left(\frac{\pi}{4} + x\right) \cos 2x$ then possible value of $\sec x$ is | 3. $\frac{1}{2}$ |
| S. If $\cot\left(\sin^{-1}\sqrt{1-x^2}\right) = \sin\left(\tan^{-1}(x\sqrt{6})\right)$, $x \neq 0$, then possible value of x is | 4. 1 |

Codes:

	P	Q	R	S
(A)	4	3	1	2
(B*)	4	3	2	1
(C)	3	4	2	1
(D)	3	4	1	2

Ans. [B]

Sol.

(P) Expression = $\left(\frac{1}{y^2} \left(\frac{\frac{1}{\sqrt{1+y^2}} + \frac{y^2}{\sqrt{1+y^2}}}{\frac{\sqrt{1-y^2}}{y} + \frac{y}{\sqrt{1-y^2}}} \right)^2 + y^4 \right)^{\frac{1}{2}} = (1 - y^4 + y^4)^{1/2} = 1$

(Q) $(\cos x + \cos y) = (-\cos z)$

and $(\sin x + \sin y) = (-\sin z)$

∴ On squaring and adding, we get

$1 + 1 + 2 \cos(x - y) = 1$

$$\Rightarrow \cos(x - y) = \frac{-1}{2} \Rightarrow 2\cos^2\left(\frac{x - y}{2}\right) = \frac{-1}{2} \Rightarrow \cos\left(\frac{x - y}{2}\right) - 1 = \frac{-1}{2}$$

$$\therefore \cos\left(\frac{x - y}{2}\right) = \pm \frac{1}{2}$$

$$(R) \quad \cos 2x \left(\cos\left(\frac{\pi}{4} + x\right) - \cos\left(\frac{\pi}{4} - x\right) \right) = \sin 2x \left(\frac{\sin x}{\cos x} - \frac{\cos x}{\sin x} \right)$$

$$\Rightarrow \sin x = \frac{1}{\sqrt{2}} \Rightarrow x = \frac{\pi}{4}$$

$$\therefore \sec x = \sqrt{2}$$

$$(S) \quad \frac{|x|}{\sqrt{1 - x^2}} = \frac{x\sqrt{6}}{\sqrt{1 + 6x^2}} \Rightarrow 1 + 6x^2 = 6 - 6x^2 \Rightarrow x = \pm \frac{1}{2}\sqrt{\frac{5}{3}}$$

But $x > 0$

$$\Rightarrow x = \frac{1}{2}\sqrt{\frac{5}{3}}$$

58. A line $L : y = mx + 3$ meets y -axis at $E(0, 3)$ and the arc of the parabola $y^2 = 16x$, $0 \leq y \leq 6$ at the point $F(x_0, y_0)$. The tangent to the parabola at $F(x_0, y_0)$ intersects the y -axis at $G(0, y_1)$. The slope m of the line L is chosen such that the area of the triangle EFG has a local maximum.

Match List-I with List-II and select the correct answer using the code given below the lists:

List I

List II

P. $m =$

1. $\frac{1}{2}$

Q. Maximum area of $\triangle EFG$ is

2. 4

R. $y_0 =$

3. 2

S. $y_1 =$

4. 1

Codes:

	P	Q	R	S
(A*)	4	1	2	3
(B)	3	4	1	2
(C)	1	3	2	4
(D)	1	3	4	2

Ans. [A]

Sol. Now, Δ = area of (ΔEFG)

$$= \frac{1}{2} \begin{vmatrix} 0 & 3 & 1 \\ 0 & 4t & 1 \\ 4t^2 & 8t & 1 \end{vmatrix}$$

$$\Delta = |6t^2 - 8t^3|$$

$$\therefore \frac{d\Delta}{dt} = 0 \Rightarrow t = 0, \frac{1}{2}, \text{ but } t = 0 \text{ (reject)}$$

$$\text{So, } F(x_0, y_0) \equiv (4t^2, 8t) \equiv (1, 4)$$

$$E(0, 3)$$

$$G(0, y_1) \equiv (0, 4t) \equiv (0, 2)$$

Now, $y = mx + 3$, satisfied by $(1, 4) \Rightarrow 4 = m + 3 \Rightarrow m = 1$. **Ans.**

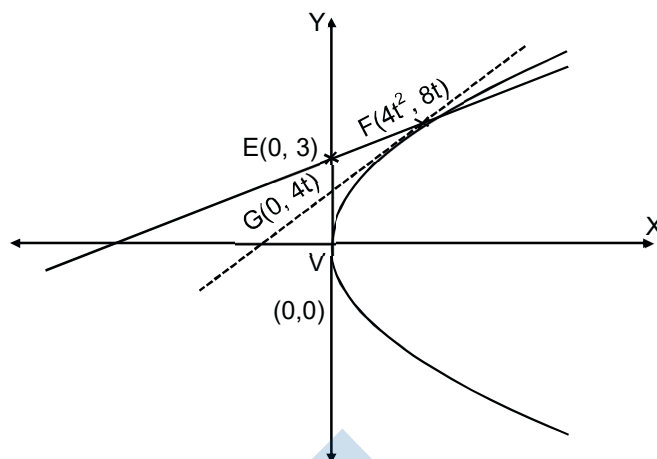

59. Match List-I with List-II and select the correct answer using the code given below the lists:

List I

List II

- | | |
|---|---------------|
| <p>P. Volume of parallelepiped determined by vector \vec{a}, \vec{b} and \vec{c} is 2. Then the volume of the parallelepiped determined by vectors $2(\vec{a} \times \vec{b})$, $3(\vec{b} \times \vec{c})$ and $(\vec{c} \times \vec{a})$ is</p> | <p>1. 100</p> |
| <p>Q. Volume of parallelepiped determined by vectors \vec{a}, \vec{b} and \vec{c} is 5. Then the volume of the parallelepiped determined by vectors $3(\vec{a} + \vec{b})$, $(\vec{b} + \vec{c})$ and $2(\vec{c} + \vec{a})$ is</p> | <p>2. 30</p> |
| <p>R. Area of a triangle with adjacent sides determined by vectors \vec{a} and \vec{b} is 20. Then the area of the triangle with adjacent sides determined by vectors $(2\vec{a} + 3\vec{b})$ and $(\vec{a} - \vec{b})$ is</p> | <p>3. 24</p> |
| <p>S. Area of a parallelogram with adjacent sides determined by vectors \vec{a} and \vec{b} is 30. Then the area of the parallelogram with adjacent sides determined by vectors $(\vec{a} + \vec{b})$ and \vec{a} is</p> | <p>4. 60</p> |

Codes:

	P	Q	R	S
(A)	4	2	3	1
(B)	2	3	1	4
(C*)	3	4	1	2
(D)	1	4	3	2

Ans. [C]

Sol. P : $||[\vec{a} \vec{b} \vec{c}]|| = 2$

$$\therefore [2(\vec{a} \times \vec{b}) \quad 3(\vec{b} \times \vec{c}) \quad (\vec{c} \times \vec{a})] = 6[\vec{a} \vec{b} \vec{c}]^2 = 24$$

$$Q : |[\vec{a} \vec{b} \vec{c}]| = 5$$

$$\therefore \left| \left[3(\vec{a} + \vec{b}) \quad \vec{b} + \vec{c} \quad 2(\vec{c} + \vec{a}) \right] \right| = 6(z)[\vec{a} \vec{b} \vec{c}] = 12(5) = 60$$

$$R : \frac{1}{2} |\vec{a} \times \vec{b}| = 20 \Rightarrow |\vec{a} \times \vec{b}| = 40$$

$$\therefore \Delta = \frac{1}{2} |(2\vec{a} + 3\vec{b}) \times (\vec{a} - \vec{b})| = \frac{1}{2} |-2\vec{a} \times \vec{b} + 3\vec{b} \times \vec{a}| = \frac{5}{2} |\vec{a} \times \vec{b}|$$

$$S : |\vec{a} \times \vec{b}| = 30$$

$$|(\vec{a} \times \vec{b}) \times \vec{a}| = |\vec{b} \times \vec{a}| = 30$$

60. Consider the lines $L_1 : \frac{x-1}{2} = \frac{y}{-1} = \frac{z+3}{1}$, $L_2 : \frac{x-4}{1} = \frac{y+3}{1} = \frac{z+3}{2}$ and the planes $P_1 : 7x + y + 2z = 3$, $P_2 : 3x + 5y - 6z = 4$. Let $ax + by + cz = d$ be the equation of the plane passing through the point of intersection of lines L_1 and L_2 , and perpendicular to planes P_1 and P_2 .

Match List-I with List-II and select the correct answer using the code given below the lists:

	List I	List II
P.	a =	1. 13
Q.	b =	2. -3
R.	c =	3. 1
S.	d =	4. -2

Codes:

	P	Q	R	S
(A*)	3	2	4	1
(B)	1	3	4	2
(C)	3	2	1	4
(D)	2	4	1	3

Ans. [A]

Sol. Any point on L_1 is $(2\lambda + 1, -\lambda, \lambda - 3)$ and any point on L_2 is $(\mu + 4, \mu - 3, 2\mu - 3)$

$$\therefore \lambda = 2, \mu = 1$$

So, point of intersection is $(5, -2, -1)$.

$$\text{Also, normal vector of required plane is parallel to vector} = \begin{vmatrix} \hat{i} & \hat{j} & \hat{k} \\ 7 & 1 & 2 \\ 3 & 5 & -6 \end{vmatrix} = -16(\hat{i} - 3\hat{j} - 2\hat{k})$$

So, equation of required plane is $1(x - 5) - 3(y + 2) - 2(z + 1) = 0$

$$\Rightarrow x - 5y - 2z = 13$$

$$\therefore a = 1, b = -3, c = -2, d = 13.$$